

The commodity chain of the household: focus on fuzziness
Ernestina Coast (LSE)
Sara Randall (UCL)
Tiziana Leone (LSE)

1. Introduction

“Household surveys provide one of the pillars upon which some of the most important innovations in economics during the last half of the 20th century have been built”

Duncan, 2008

Household surveys are the mainstay of micro-level data for developing countries. They can provide the data for more than half of the MDGs, and are particularly important in resource-poor country settings where data cannot be produced by routine or administrative data systems. Household surveys identified as key to MDG monitoring and evaluation include LSMS, DHS, MICS, Child Labour Surveys, World Health Surveys, and CWIQ¹. Household surveys are the “starting point” for poverty measurement (World Bank, 2008), and the World Bank alone recorded data from 675 household surveys from 115 developing countries between 1979 and 2007. There has been an “explosion” in the number of household surveys conducted post-1950 (Duncan, 20008).

The importance of household surveys continues to be underscored by, for example, the Partnership in Statistics for Development in the 21st Century (PARIS21)², and they are a vital ingredient for development planning, including the production of poverty maps (Bedi, Couduel & Simler, 2007). The Marrakech Action Plan for Statistics (MDR, 2004) emphasises the need to improve the collection and use of existing nationally representative household surveys rather than develop entirely new data collection mechanisms (Action 4). In developed countries, in addition to census and routine statistics, micro-level data collection includes increasingly complex longitudinal household surveys, underscored by sophisticated data management, maintenance and analyses. In developing countries, with the exception of a limited number of prospective surveys³, cross-sectional household surveys are the “bread and butter” of research based on household surveys (Duncan, 2008).

1.1 The commodity chain of the household

The concept of a commodity chain originates from disciplines allied with economics and in short, a commodity chain is the “connected path from which a good travels from producers to consumers⁴”. It is a series of complexes and processes that result in a completed commodity. These complexes, networks and processes are “situationally specific, socially constructed, and locally integrated” (Gereffi et al, 1994). The commodity chain idea has also been developed to include analyses of the human relations along the chain of production (Ribot 1998) We extend this idea of the commodity chain in order to understand the transformations of data on households produced by surveys., from conceptualization to production to consumption. The chain of production of household data has two origins (fig 1) one being the statistical data chain from conceptualisation, through field work to report. The other origin is that of the actual household: the object about which data are being collected.

¹ World Bank: Living Standard Measurement Surveys. USAID: Demographic and Health Surveys. UNICEF: Multiple Indicator Child Surveys. CWIQ:Core Welfare Indicators Questionnaire

² Founded in 1999 By the United Nations, the European Commission, the Organisation for Economic Co-operation and Development, the International Monetary Fund, and the World Bank, in response to the UN Economic and Social Council resolution on the goals of the UN Conference on Development

³ See INDEPTH network <http://www.indepth-network.org/>

⁴ http://en.wikipedia.org/wiki/Commodity_chain

Figure 1: Commodity chain of the household

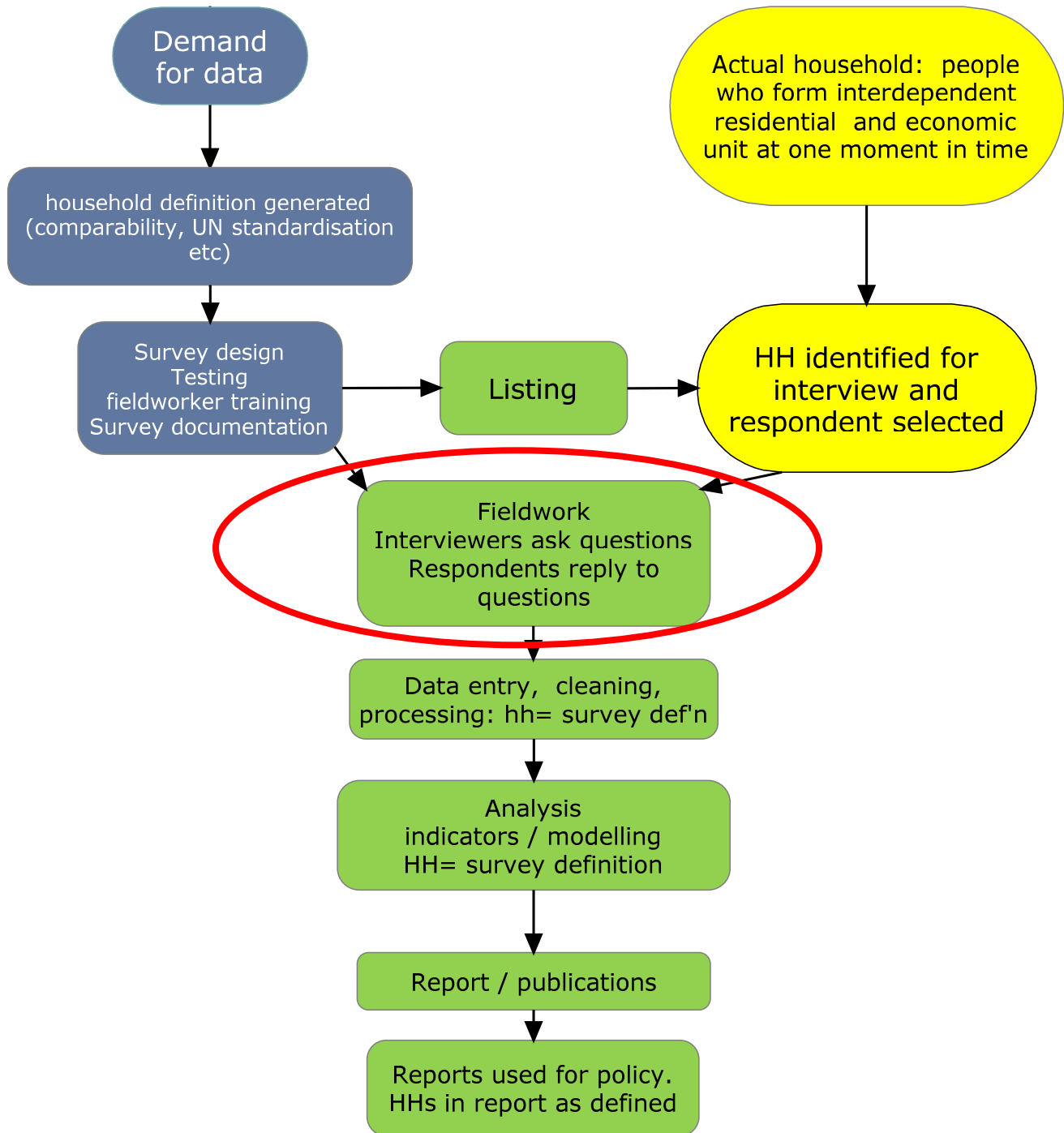

Each node represents different steps in the production of data on households involving inputs, processes and outputs, with interaction between each of the nodes. The interaction of the nodes is “socially shaped.” (Gereffi et al, 1994) In this paper we focus on one part of this chain: the

interactions between data collectors and survey respondents (red circle, Fig 1.) although our larger research endeavour analyses its entire length.⁵

We hypothesise that the idea of household means different things to different players involved at different nodes of the chain but that all use the same vocabulary so that these ambiguities are usually invisible or even unknown. Here we examine one node in detail: the interface between data collection and survey respondents. Is the definition of a household viewed or perceived as problematic by those people that do the data collection for household surveys? Is it problematic for respondents in household surveys? Is there evidence that in the negotiations between the two, important dimensions of the household as a fundamental social unit are lost?

1.2 Being fuzzy

“I coined the word "fuzzy" because I felt it most accurately described what was going on in the theory. I could have chosen another term that would have been more "respectable" with less pejorative connotations. I had thought about "soft," but that really didn't describe accurately what I had in mind. Nor did "unsharp," "blurred," or "elastic." In the end, I couldn't think of anything more accurate so I settled on "fuzzy".”

Quote from Zadeh (man accredited with developing fuzzy thinking back in the 1960s)

Fuzzy attributes were developed in mathematics, computing and related disciplines in the 1960s, referring to fuzzy sets that were defined so as to allow for imprecise membership criteria and for gradations of membership. By extension, fuzzy logic refers to the logic of fuzzy sets and fuzzy concepts. Methodological innovations in the social sciences more generally have included, for example, the development of Fuzzy Set Qualitative Comparative Analysis (fs/QCA)⁶, fuzzy cognitive maps⁷, and Fuzzy set theory⁸.

Social science has begun to incorporate notions, concepts and techniques of fuzziness into substantive research⁹. Although representing a wide range of disciplines, approaches and settings, researchers are clear that use of fuzzy concepts does not relate to lack of clarity or endeavour. Rather, what this research has in common is a need to move beyond established boundaries and norms in order to represent reality better. This work, although disparate in terms of topic, time and geography, is united by attempts to try to deal with complex and unpredictable scenarios that are subject to considerable uncertainty. It is interesting that many of them involve the study of migration – long considered the most poorly articulated of the three key components of demography.

Demographers have used the adjective “fuzzy” to refer to demographic states and processes, including Coleman (2004) – migration; Philipov (n.d.) – cohabitation and migration; Knab (1995) – cohabitation,

⁵ ESRC-funded project “The commodity chain of the household: from survey design to policy analysis”

⁶ Uses fuzzy membership of sets in order to do Qualitative Comparative Analysis (QCA), an analytic technique that uses Boolean algebra to implement principles of comparison, used in the qualitative study of macro social phenomena

⁷ A mental map within which the relations between the elements (e.g. concepts, events, project resources) of a "mental landscape" can be used to compute the "strength of impact" of these elements.

⁸ Allows the description of systems, which are either too poorly defined or too complex to be amenable to precise mathematical description.

⁹ For example, Banks (2003) – fuzzy boundaries of group tenure related to pastoral rangeland in China; Currie + Stanley (2008) – social capital; Danson (2007) – regional analysis; Descola (2005) – anthropology as a discipline; Eriksen (2007) – complexity in migration and ethnicity; Hyowon + Ola (2009) – geospatial concepts; Muula (2007) – the concept of rurality; Naidoo et al (2005) and Ngwaane et al (2001) – poverty; Phillis et al (2001) sustainability; Smart (2003) – citizenship; and, Voas (2009) – fidelity.

Antoine and Lelièvre (2009) union and separation, pregnancy, being housed, adulthood. Whilst not using the term fuzzy, yet others consider related issues such as “boundary ambiguity” as related to the concept of the family (Brown and Manning, 2009). A limited number of demographers have suggested that extending mathematical use of fuzzy sets theory and logic to technical demography could yield fruitful development (Murphy, 1996; Imhoff, 1995; Goldstein *et al*, 2000)

1.3 Drawing together fuzziness + commodity chain + household surveys

In this paper we develop the conceptual idea of fuzziness to think through dimensions of household fuzziness and implications for production and consumption of household survey data. A fuzzy concept may at first appear oxymoronic. The suggestion that the concept of the household as it used in household surveys is fuzzy will be anathema to those trained in survey data collection. Fuzziness does not, however, mean that the concept of the household is an inherently bad concept or is impossible to operationalise. Rather, we use the term fuzzy to shed light on our hypothesis that different users of the concept of household think that they are considering the same thing, but are in fact considering a range of different meanings and attributes.

Household surveys, by definition, require a household to be identified. In social science, the household is the “building block” (Bolt, 2003) for much data collection and subsequent analyses, even though the household is a contested and problematic concept across disciplines, time and space (Bender, 1967; Yanagisakop, 1979; Netting *et al*, 1984; Bruce and Lloyd, 1992; Rogers & Schlossman, 1983; Van de Walle, 2006; Hoffmeyer-Zlotnik & Warner, 2008). The UN (1997) defines a household as ‘based on the arrangements made by persons, individually or in groups, for providing themselves with food or other essentials for living’. This definition is somewhat Eurocentric, lending itself well to representing stable nuclear conjugal family units, but more problematic when forming the basis for data collection in sub-Saharan African countries where prevailing models of social organisation may be much more diverse and flexible (van de Walle 2006). Whilst this minimal ‘household’ may be an effective practical definition for a *de facto* census as a count of population, it is much less useful if one wants to understand social and economic dynamics at the level of the locally important social unit, itself also understood by both researchers, analysts and policy makers to be something called a ‘household’.

Thus, despite recognizing that, *‘the household is central to the development process. Not only is the household a production unit but it is also a consumption, social and demographic unit’* (Republic of Kenya, 2003:59), the unit used in most household surveys is usually not the locally understood and lived basic social unit. A review of survey documentation reveals that most manuals take the definition of a household for granted, often based on the census definition yet the census is not a good basis for survey definitions of a household because a census has very specific needs – to enumerate each person once and once only. A review of the DHS precursor, the WFS, concluded that there was a serious lack of evidence about the extent of error due to ambiguous household definition (Scott and Harpham 1987), but no analyses were published. The result is a type of ecological fallacy. By collecting data on the household, even if these data are at the individual level, an *a priori* and acontextual definition of the household, forces conclusions to be drawn about something (a survey household), that in reality might not exist. Imhoff argues that “*definitional problems* [author’s italics] are particularly strong in household and family data”, both in terms of the relationship between individuals and the classification of groups of individuals (2001:xxxx) and Keilman (1995) demonstrates how changes in household definition can affect comparisons and projections across time and space.

This paper does not set out to review or critique the definitions used by household surveys¹⁰ nor do we propose to redefine the household. Given the heterogeneity of human societies it is unlikely and undesirable that one definition will fit all situations¹¹. Furthermore we are not proposing that the household be abandoned in favour of the family¹², even though the two frequently overlap and intersect in reality. Most social science disciplines are clear (at least to themselves) that the two concepts are distinct (Burch, 2001; Yanagisako, 2001), and that it is possible to have non-family households.

2. Methods

We use a country-level case study approach in order to examine intensively the concept of the household as it is produced and used along the commodity chain of household data production and use. We focus on one part of that commodity chain (Fig 1) – between the nodes of data collection and survey respondent(s). The case study was identified as the most appropriate research strategy in order to answer the research questions by generating “thick, rich, detailed” (Wolff, 2007) data and explanations of how ‘household’ is understood by different players. Multiple methods were used to document the complexities surrounding the concept of the household in order to triangulate and allow us to draw the strongest possible inferences.

We undertook the research in Tanzania and we assume that the commodity chain of the household in Tanzania is not markedly different from that operating in other parts of Anglophone sub-Saharan Africa. Every country will have contextual specificities – not least in terms of linguistics – but Tanzania has sufficient commonalities with other sub-Saharan African countries to allow for generalisable statements to be made about household surveys in sub-Saharan Africa.

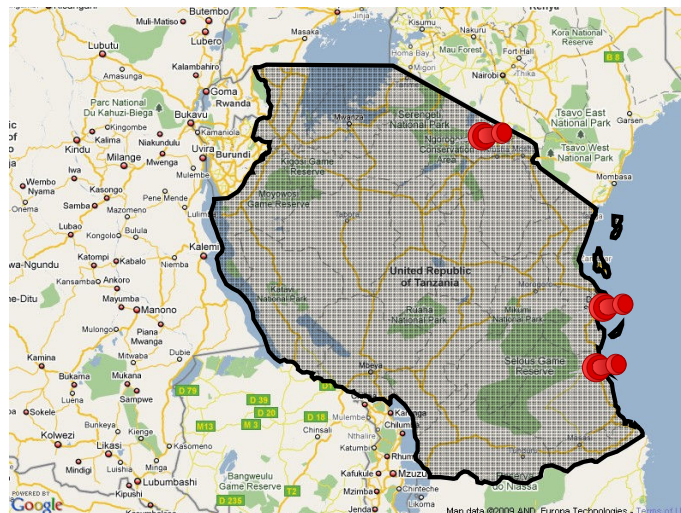

Figure 2: Study site location

¹⁰ The project does do this elsewhere, having reviewed definitions of the household as used by major household surveys in sub-Saharan Africa post-1950.

¹¹ Basch et al (1984), for example, propose transnational households – a concept which would be contested by those who argue that a household is based on coresidence. Burch (2001), on the other hand, suggests that “The central idea of the household concept is that of *coresidence*: a household is a group of persons who ‘live-together’ day-to-day, or an individual ‘living alone.’”

¹² Generally defined on the basis of kinship, with a range of typologies, including: extended, nuclear, conjugal. Thornton and Fricke (1989:130) “family... a social network, not necessarily localized, that is based on culturally recognized biological and marital relationships”

Our analyses here are based on two principal research methods, reflecting an iterative and interpretative research process to focus on the interface between survey respondents and survey data collection.

1. Qualitative in-depth interviews (n=39) with key individuals situated at different places on the chain of demographic data collection and analysis. Recorded interviews were transcribed verbatim and coded using N6 to facilitate analysis¹³. Key themes for coding were developed based on research hypotheses but further codes were developed inductively after reading and re-reading all interviews. All interviews were coded independently by two researchers.
2. Case study interviews in a range of settings with Tanzanians about the membership of their household and the residence, production and consumption of household members.
 - a. Dar Es Salaam: Interviews (n=24) were undertaken in two different low income areas of Dar Es Salaam using four experienced interviewers from a university-based consultancy. Participants were organised in advance to expect us, and told the basic aims of our interviews, through personal contacts and local leaders, resulting in high levels of cooperation. Our fieldwork supervisor selected a range of different household types and circumstances, and the interviews involved one of the authors working with an experienced interviewer. Most interviews were recorded and all were in Swahili.
 - b. Maasai agropastoralist community: Interviews (n=8) were collected using a university educated interpreter from that community who had previously worked there as a research assistant for an anthropologist who was also present, having worked on the literature review for this project. Both knew the households and respondents well and provided supplementary information for triangulation. A further interview was undertaken with one Swahili household living in this area. Given the size and complexity of Maasai households these interviews covered the equivalent of about 20 DHS defined households
 - c. Rufiji community Interviews (n=20) were collected by a research student with in-depth knowledge of the community and its setting¹⁴.

We developed our interview approach out of cognitive interviewing (Willis, 2004), making it clear from the beginning that there were no clear right or wrong answers, that we wanted to explore and understand diverse living arrangements and encouraged respondents to talk about individuals whose status with respect to that living unit might be ambiguous. Often two or three respondents were present for the interview and frequently younger members reminded older males about the existence of various children. We emphasised that this was not part of a larger survey and was just a small, one-off study. Groups a and b were given a small remuneration for their time.¹⁵ At the beginning of each interview the interviewer explained that we were particularly interested in everyone who belonged to that '*kaya*' and that we wanted to know who they thought were members of their *kaya*, whether actually present or not¹⁶. Using a

¹³ At the end of the research project all interviews (suitably anonymised) will be made available via the ESRC Qualidata archive. Permission has been requested from all respondents to quote from their interview. Requests for anonymity have been followed and it is made clear where individuals are speaking in a personal rather than institutional capacity.

¹⁴ Need to complete

¹⁵ In all cases respondents were extremely happy to participate and in the two research sites where PhD students had undertaken long term work in the community they both commented on the willingness and interest of the participants compared to other forms of data collection. Group c was not remunerated because the student concerned was still working in the community and did not want to generate future demands for money.

¹⁶ We explained that we were interested in those who they thought were part of their local unit and not just those people registered as being the '*kaya*' members on the 10 cell unit lists.

household grid similar to those used in major household surveys (but with considerable space for written comments) we listed all the members in the household as reported by the respondent and not as dictated by a predefined definition. After obtaining a list of *kaya* members we asked about relationships and marital status, location of absent people, details of people who had slept there last night, sleeping and eating arrangements both the previous night and more generally, sources of income and support and links with other households either through providing or receiving economic support. Limited questions on asset ownership were asked. This information was meant to establish the discrepancies between some of the key concepts usually conceived to define the household such as eating and/or sleeping together and what interviewees consider as THEIR household. The open and discursive questioning also allowed for discussion around household members whose status was ambiguous even for the respondent. Reasons for such ambiguity were discussed as were situations of membership of multiple households.

Our interviews were not strictly cognitive interviewing which is designed to test respondent's understanding of survey questions. However building on the ideas behind cognitive interviewing respondents were encouraged to reflect on what made people a member or not of their household and whether these were economic, emotional, supportive or other ties and obligations.

3. Results

Analyses of in-depth interviews with both key informants and Tanzanian residents identified 5 themes that begin to unravel and identify some of the sources or causes of fuzziness underlying the concept of household between data collection and respondents.

1. Complex concepts: household or family or house
2. (Non-)overlapping dimensions: residence, eating, sleeping, sharing of economic resources and responsibilities
3. Household head
4. Children and older people
5. "Infamous fuzziness": pastoralists and polygyny, fishing communities

3.1 Theme 1: Complex concepts: household or family or house?

The concept of the household for both survey professionals and respondents is highly ambiguous, often interchangeable with "family" or "house". The example of Janeth's situation demonstrates how elision of the concepts of household and house can lead to household members being omitted from the original household listing.

Janeth (widowed, 38 years old) lives in a high density suburb Dar Es Salaam. She self-identified herself as the household head. When asked about members of her household (*kaya*), she initially listed 4 of her own children and 2 of her dead husband's nephews (both of whom had lived with her since they were young) (Fig. 3).

Fig 3: Janeth (Dar es Salaam)

Listing of household (*kaya*) members

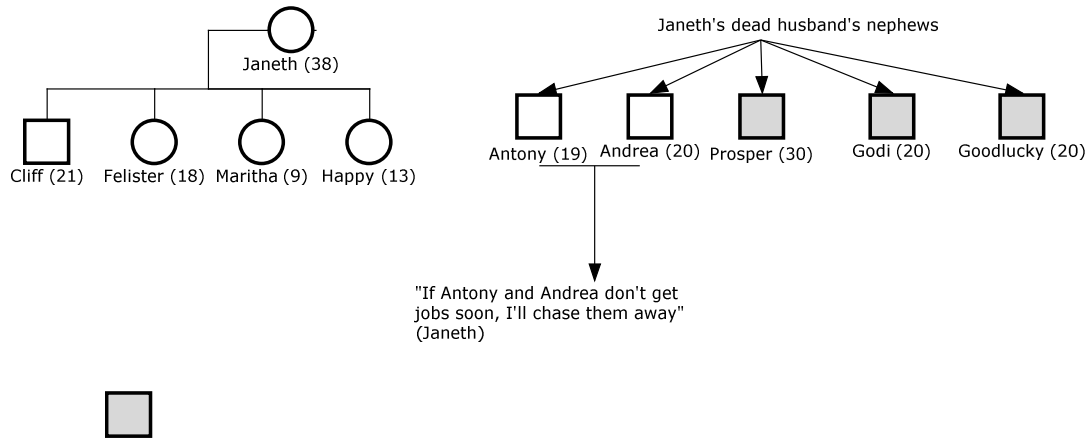

Figure 3b: Janeth's household: sleeping arrangements

Slept here last night

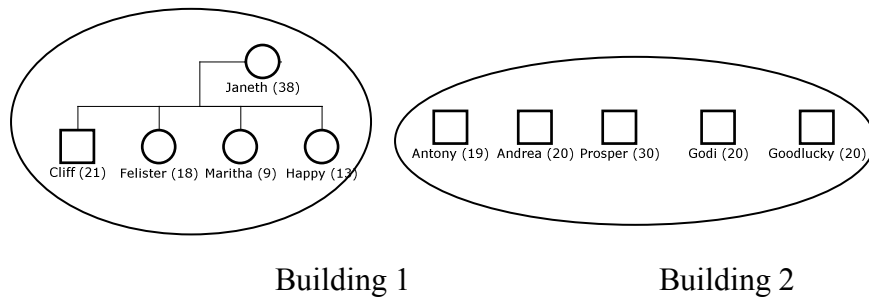
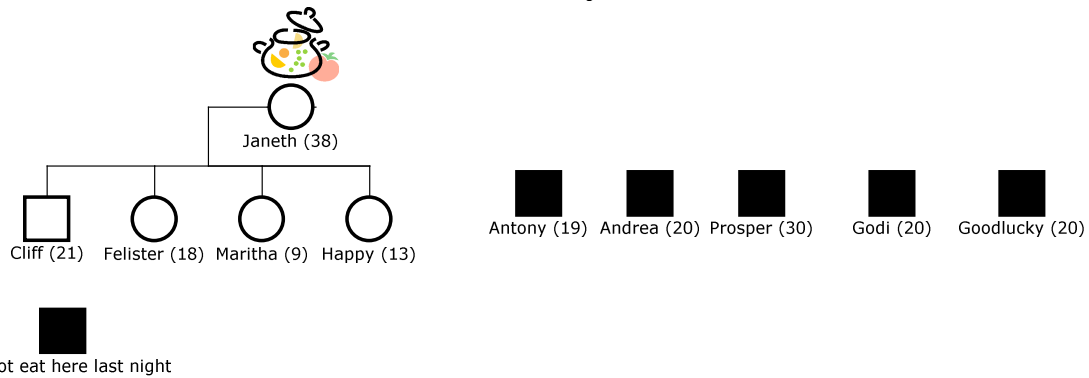

Figure 3c: Janeth's household: eating arrangements the preceding evening

Ate here last night



Subsequently discussions revealed three further resident nephews of her dead husband. The three "forgotten" nephews have lived in a (rather wrecked) building on her plot for over a year, having

migrated to Dar es Salaam from the north, did not pay rent and often, but by no means always, ate with Janeth, occasionally giving her some money towards their upkeep. Janeth did not hesitate to include the two (of her husband's) nephews who had lived with her since they were young but was ambivalent about whether the other three were part of her household because they were not fully economically dependent on her – on the other hand she provides them with free accommodation and some food, especially when they are down on their luck. One of the reasons they live with her is in order to bolster her position in a family dispute over the (very valuable) land on which the houses are built. All *kaya* members slept there last night, distributed across two separate buildings. (Fig 3b) Two of the nephews normally eat from Janeth's kitchen, the other three occasionally, but the night before the interview, they had all eaten elsewhere (Fig 3c).

Throughout the study, but particularly in urban settings, young men were identified as being particularly irregularly present at mealtimes, even if they were members of a household that had access to cooking facilities. Janeth's household also illustrates issues around the recording of relationships in surveys. If relationships are just recorded with the head of household all of these nephews would appear as unrelated (because they are her dead husband's relations). However their relationship to her husband and to each other was clearly an essential dimension of their presence in this household.

An interviewer who had worked on at least 3 DHS surveys in Tanzania demonstrated the fluidity of the use of terms across family, household and house, using the words interchangeably in response to our questions about the household.

- I we've been told different words for household... would you ever use *kaya*?
- R *Kaya*? Oh yes. *Nyumba* [=house], *kaya*, that is the household, *kaya*...
- I So who does not know *kaya*?
- R Some people, other people, they do not know *kaya*.
- I ...when you say that they don't know *kaya* is that because *kaya* is a very special word or just educated people know it?
- R Not used sometimes, they use *nyumba* [=house]
- I Would people or interviewers like you, would they ever use *familia*?
- R *Familia*, yes.
- I They would use that as well? OK, when you are trying to make people understand
- R *Familia ya kaya*
- I *Familia ya kaya* - family of this household. OK. **DHS interviewer**

In another household from Dar es Salaam, even though Rashidi was asked explicitly about his household (*kaya*), he originally only listed 6 people (Fig. 4a) despite the fact that the others were all in the room during the interview. Here Fatuma owned the house where they all lived, having inherited it from her first husband. This probably explains why Ramadhani (Fatuma's son by her first marriage) and his daughter were included in the original listing, whereas Rashidi's siblings and their children were excluded. It is unclear why Halima, Ramadhani's wife was originally excluded and only added in when a specific question was asked about the whereabouts of Sabrina's mother. Rashidi was insistent that Ramadhani was a member of his *kaya* because he is not financially independent. Everybody recorded in Fig.4a lives in the same building, but each married woman has her own cooking pot (fig 4b). Usually, each of them cook and then the food is pooled for communal eating. Each married woman is given money by her husband to buy food, but if someone is short of income, then the others will contribute more food

Fig. 4a Rashidis’s household (Dar es Salaam)

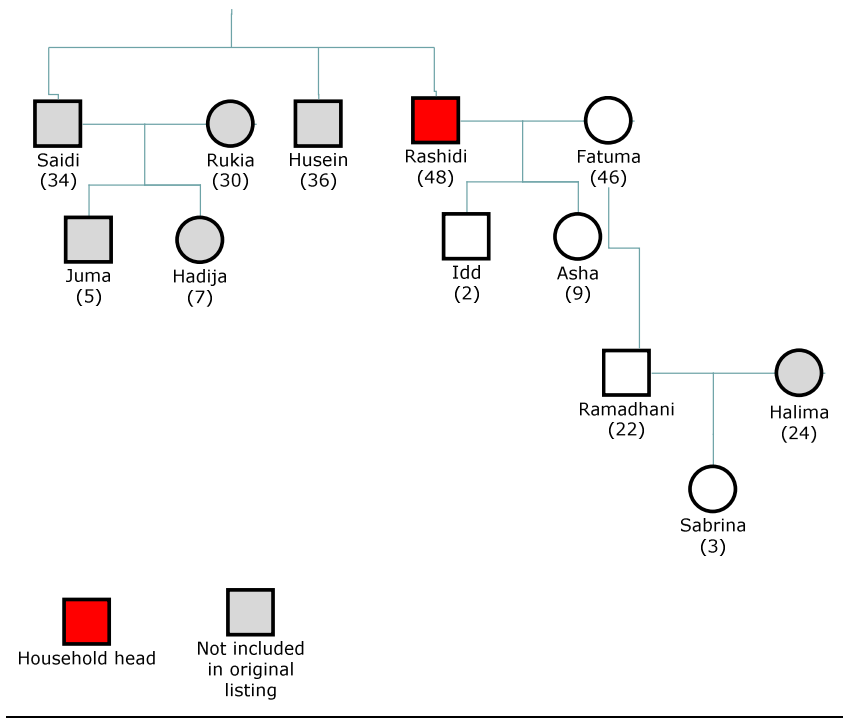
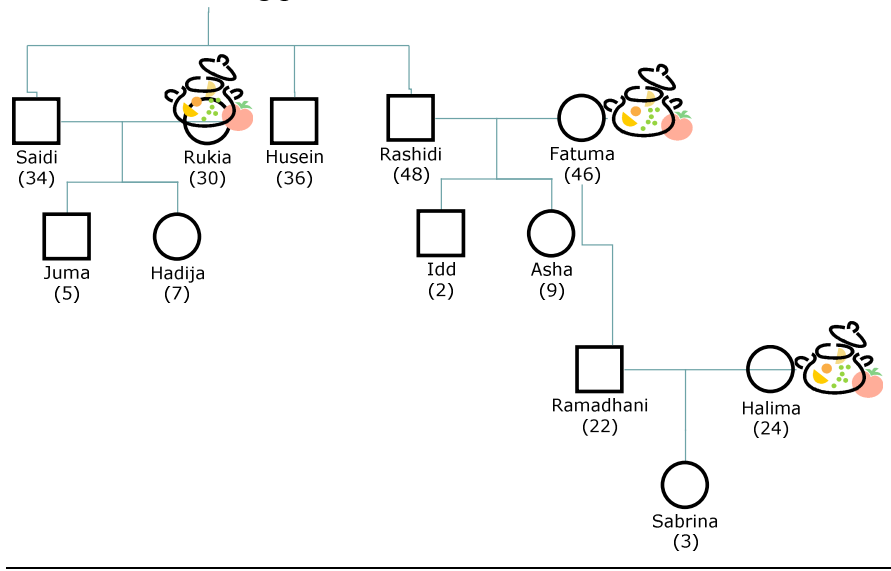

Fig 4b: Rashidi’s household: cooking pots



Everybody ate there last night, and everyone had some food contributed by all 3 cooking pots. Rashidi’s *kaya* operates as one economic unit, sharing food and daily consumption across the members. It is likely that applying DHS style definitions would generate three separate households, rather than the single large multi-nodal household living under one roof and one economic consumption unit but with three different cooking pots. Under such a scenario it is useful to speculate about how Husein, the household head’s unmarried adult brother would be dealt with. He ate from all three cooking pots the night before and slept there last night, contributing his wages from working in a restaurant. It is unclear to which household Husein would be “attached” in a household survey.

Differences in language were also associated with processes of development and modernisation in Tanzania, articulated in terms of comparison between urban and rural, between tradition and modernity.

- I ..it has become a normal, common usage word? Everybody knows kaya?*
R But in most areas they confuse it with family.
I Most non-statisticians!
R Yes, the non-statistician, they confuse kaya and family, and, it's, we live in families. Most of Tanzanians are rural, in rural areas we live in families....But in urban areas kaya is the common one. Households are common in urban areas than in rural areas. In rural areas you are families. But with urban areas you get households.
I So people will use the word kaya in normal conversation in urban areas?
R Yes, they use it.
I But in rural areas they will use family?
R Yes

Statistician from NBS

3.2 Theme 2: (Non-)overlapping dimensions of definition: residence, eating, sleeping

In any society there are complex social processes through which individuals (re)negotiate access to household resources (material, social and psychological) – sometimes daily, sometimes on a recurrent basis. In terms of the sorts of resources used in household survey definitions, this can include sharing food and a place to sleep. Tanzania is undergoing rapid social change which includes a whole range of forms of labour migration and new needs and contexts with respect to accessing food and shelter. Both old traditional links of solidarity, based largely on kinship, and new dependencies and solidarities based on economic contracts, common interests or experience mean that the units that might be referred to as households are dynamic and the product of time and space specific negotiations. As social institutions they have permeable and porous boundaries, with dynamic membership, means that residence, eating and sleeping often do not overlap neatly

Patrick (45 years) and his wife rent one room in a 6 room renting house in Dar Es Salaam with their two daughters (Maria – 15 years and Neema – 12 years). The previous night Maria had neither eaten nor slept with her parents and sister. Every weekend she travels to her aunt's house elsewhere in Dar Es Salaam. Maria is a secondary school student and her aunt is a teacher and has a house with electricity, so Maria can study at weekends. The aunt pays for Maria's upkeep at weekends. A de facto household definition would have recorded a three person household based on either sleeping or eating the previous evening, excluding Maria, yet her parents provide much of her support and see themselves as a 4 person household. The aunt (not interviewed) probably also sees Maria as a regular but transient member of her household.

Particularly for unmarried adults, tenuous and variable employment or income, means that sharing resources, including food, and accommodation is a key risk minimisation strategy

In the case of these people they are renting rooms. They are people from upland. They have come to Dar Es Salaam because of employment...So before he gets employment he has to find a way of living. A brother or a sister or a relative would accommodate him...Then they can stay a long time before they get employment...

Professional interviewer

Articulating household membership can be complex even when the household involves as few as two people. Godfrey (22 years old) lived in a single room in a larger building owned by his mother. Within the building there were 5 other rooms, each rented out. A trained electrician, he is currently unemployed, so manages the rental property, collecting the rent on behalf of his mother. Towards the end of the interview, when asking Godfrey about where he ate last night, and if he cooked for himself,

he remembered Claude, his cousin. Claude shares Godfrey's room and bed, they both sleep there, and cook together. Despite this proximity Godfrey would not consider Claude to be a member of his *kaya*.

The complex process of negotiation around the practicalities of delimiting households, is demonstrated in this interview with an employee of the National Statistics office who had worked as a survey supervisor, dealing with interviewers' queries during fieldwork..

I Were there ever any cases where interviewers or enumerators would go into a household and they'd say "OK, we just want this smaller unit" and then the people in the household would say "But no, no we are one big unit"?

R Yeah, yeah it has happened.

I And were there cases where the enumerators had problems with the respondents, or whether they have to come to you to resolve these problems?

R Exactly, that was the main problem actually as far as the Lake Zone families were concerned. They have their own way of beliefs. "No, we are together, we are all eating here, my son's wives cook by rotation, we eat here". You'll say "Well it's not the case...but actually with this refined definition, if your son is married he keeps his own children, he buys clothing for the children, he cares for sickness of the family, that's the immediate family. Even though you come and eat together...you advantage each other but he has his own cost of raising up his family. So this was the problem. So some interviewers come back to me and they say, "But X, they say they are one household". Then I go with him and I explain what we mean – more than by sharing food but this one has so many responsibilities to his or her own families.

NBS supervisor and statistician

Household surveys collect data on "households" that are clearly defined by survey documents and designers. However, it is the interviewers themselves who have to negotiate with respondents in order to get what it is that the survey wants, even if that definition does not concur with the respondent's own perceptions. Key informant interviews demonstrate how data collectors apply the survey definition of a household, even though respondents consider that they were being asked to report themselves in ways that were at best contradictory, and at worst wrong, in terms of resource production and consumption. Often the data collectors and researchers were themselves uncomfortable with the impact of the definition of representing reality, although some Tanzanian researchers were more concerned about the necessity for standardisation and conforming to the official definitions

I ...let's take the DHS, do you think that it [DHS household definition] is a good representation of people's actual living units in rural areas, in urban areas?

R yeah that one I'm very sure... because when they are doing, when they are doing the listing what they usually do. You know we have a very nice structure. What they use is the data from the village register where each page register one household and the definition of the household there are the people who are eating in the same pot and even if you go to a bigger round where they have several people in, if they don't cook together, they are not registered as one household. They register several households in one place. So for the household, I am not, there is no doubt they are using the same definition because of that. Because when they are using the listing what they do they have to go to the village, and the village will assign them to the hamlet chairperson who have several household so the definition of household for him also is important.

Tanzanian Researcher trained in Demography, works for international organisation

Hamisi's household from Dar Es Salaam demonstrates the many layers of complexity around household membership, not just in terms of cooking and sleeping, but also in terms of individuals who

transition into and out. Living in one building are Hamisi and his wife, three children, 6 grandchildren and 3 great-grandchildren, with members who both ate and slept there the night before, neither ate not slept there the night before, or did just one of eating or sleeping there the night preceding the interview.

Fig 5a: Hamisi’s household (Dar es Salaam)

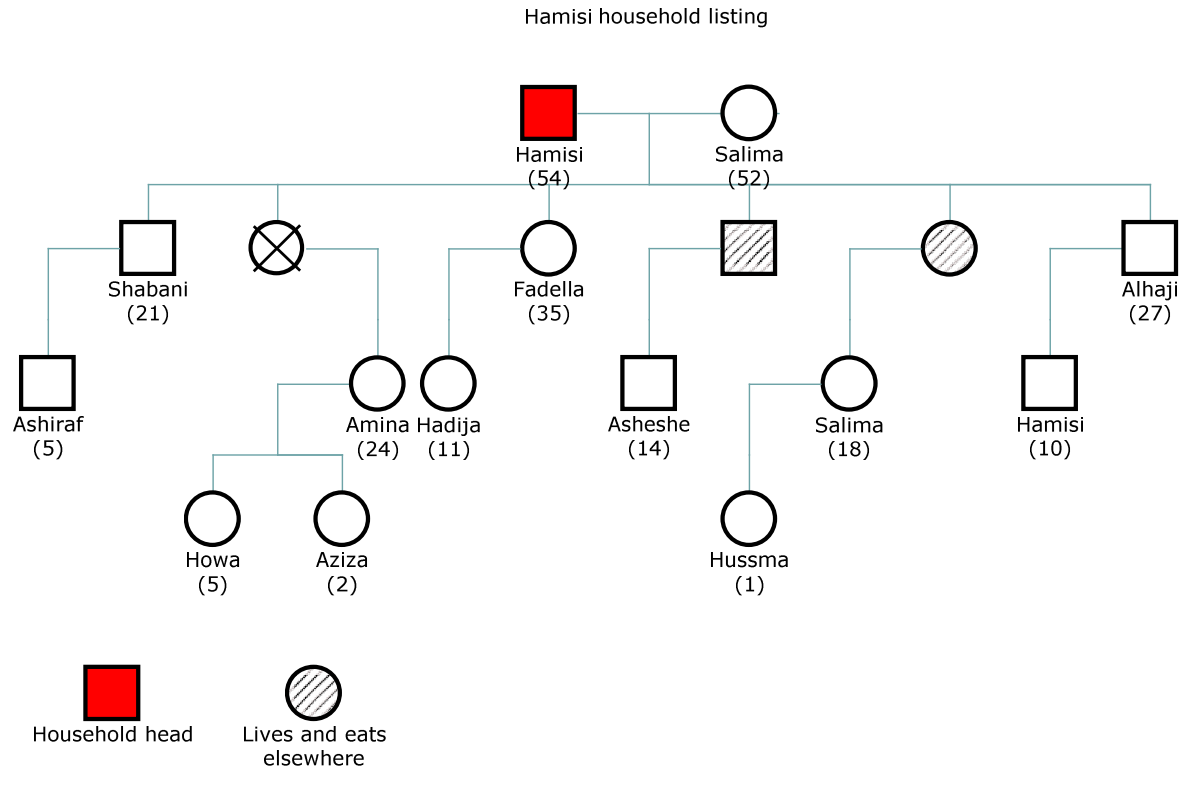

Amina, for example, ate here last night before leaving to go and stay overnight in the house of a relative who had just died. Amina’s five year old daughter, Howa, had been away staying elsewhere in Tanzania with her grandfather for the preceding 3 weeks.

Fadella, the widowed daughter of the household head had been away for a fortnight, selling wigs in Zanzibar. Her daughter, Hadija, also recorded as not having eaten or slept there the night before, was staying elsewhere in Dar Es Salaam in order to care for sick relative. Fadella’s membership of this *kaya* was discussed at some length for clarification because she has a non-co-resident boyfriend with whom she sometimes spends the night. Her father, Hamisi, felt that for now he would still consider Fadella a member of his *kaya*, but that this was something that might shift if she spent more nights with her boyfriend.

Hamisi household: ate last night

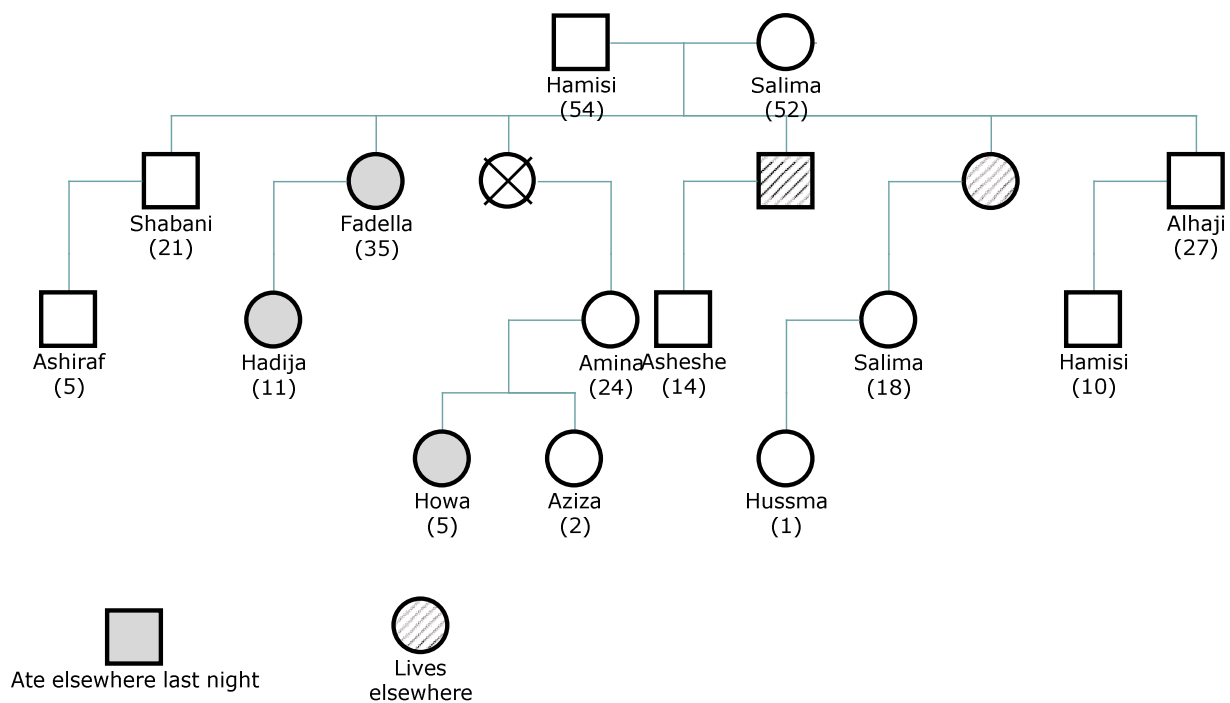

Hamisi household: slept last night

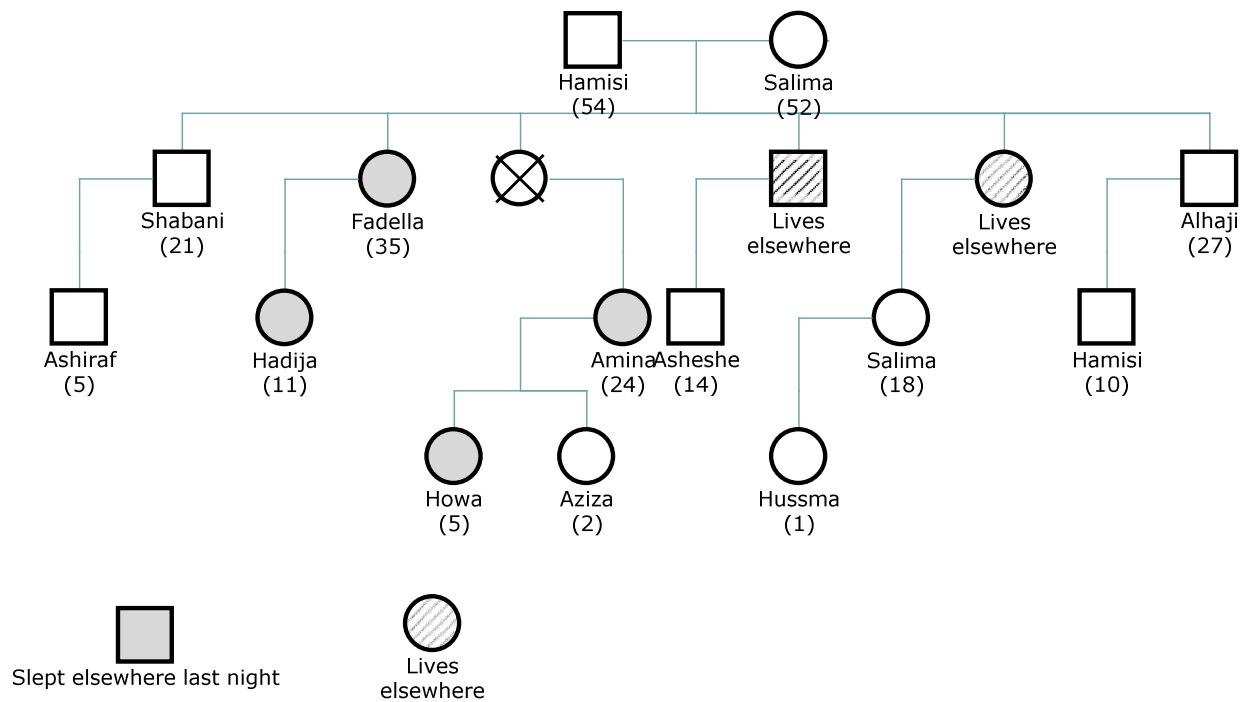

Abiba lives in Rufiji, her husband died two years ago, and her co-wife moved to live elsewhere. As self-defined household head, her household consists of an unmarried adult son, an orphaned grandchild, two married sons and their wives and children.

Figure 6a: Abiba (Rufiji)

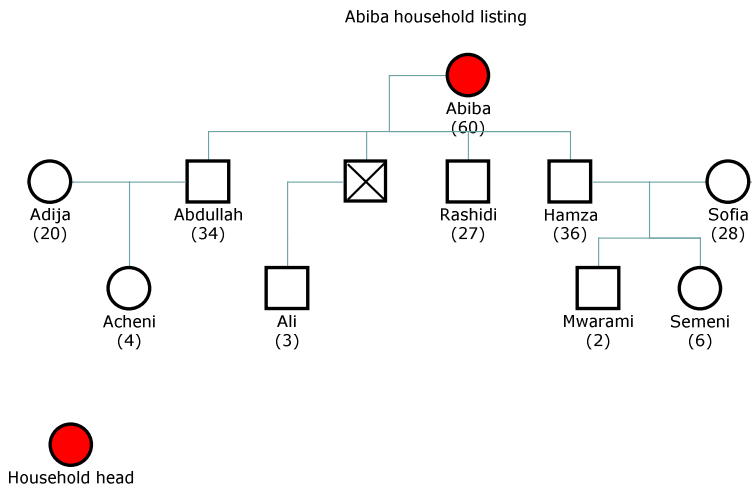

However, the number of potential households becomes increasingly complex if attributes such as eating and sleeping are considered (Fig.6b).

Fig 6b: Abiba eating and sleeping

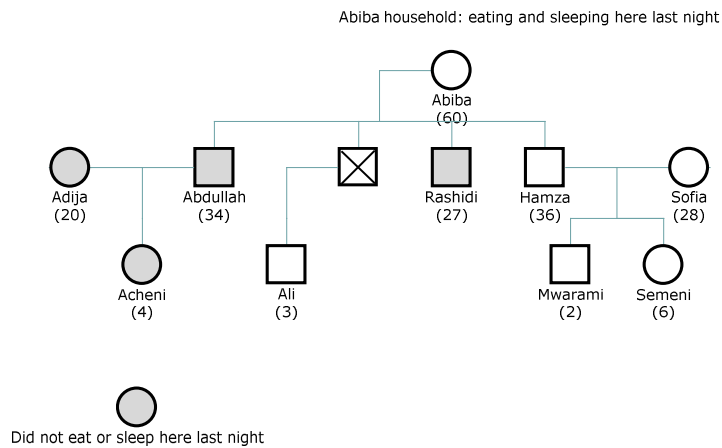

Rashidi, the unmarried adult son has been away in Dar Es Salaam for the last 4 days where he does business selling beds. Abdullah, his wife and child, have been away for at least 10 weeks. They have been working and living temporarily on the family’s plot (*shamba*), producing for the group as a whole, not just for themselves. The conceptualisation of who is, or is not, a member of the *kaya* becomes further complex when the ownership of cooking pots is considered (Fig. 6c)

Figure 6c: Abiba’s cooking pots

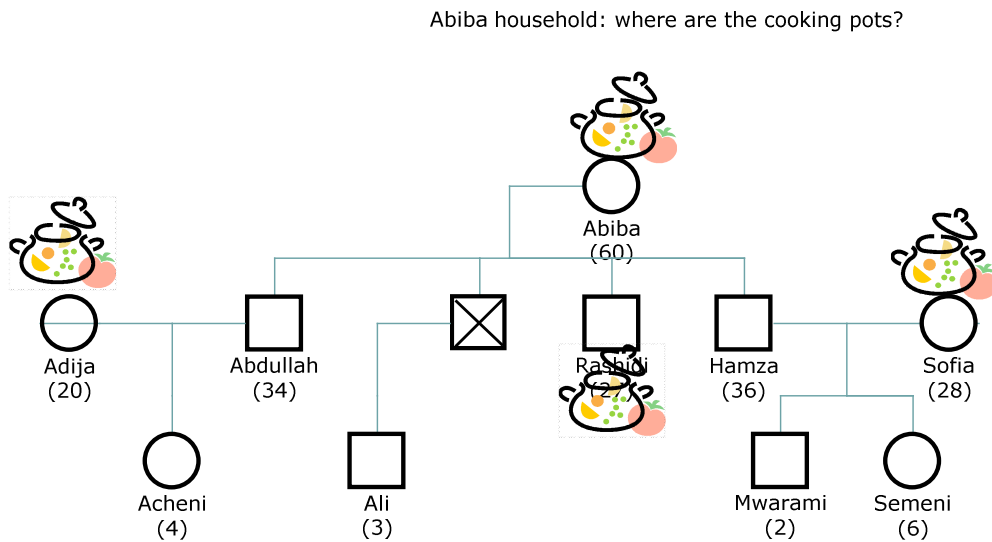

There are four cooking pots, distributed across the group, but consumption from those pots rotates, dependent on who has food resources. Finally, there are four different housing units, corresponding to the cooking pots. Our detailed interview with Abiba produced one large household, with shifting production and consumption patterns across the group, based on her self-definition. It is likely that a standard survey instrument would record four separate households, including Rashidi as a single-person household.

3.2 Theme 3: Household headship is problematic and contested

Household headship is a common dimension of survey data collection. Household rosters generally start with household head, and many African surveys include “answer to a common head” as part of the definition of a household. At the interface between data collection and responses, there is a mismatch in purpose for, and understanding of, what a household head is. For survey designers, and the interviewers who have to negotiate with respondents on the designer’s behalf, identification of a household head is often little more than an organising principle in order to identify a key contact person, with a view to getting permission to ask the questions. From the perspective of data collection, the characteristics of that household head are secondary. They are most interested in identifying someone to talk to.

But the head of the household as a definition maybe it fits much more to people who are blood related. But for those who are not blood related the head of the household is just “Let’s decide, Ok now I’m going to be the head”But the aim of the head to our definition is not to give them power, it’s just to identify them when we come back. Who do we trust, so that’s the whole aim of the head... It’s just a reference point

NBS statistician and supervisor

Enumerators are trained to ask for the head of the household (lit. trans. *mku wa kaya*), but rather like the fluidity in the use of the terms household, house and family, they also use the Swahili word “*mzee*” - a gender-specific term of respect, generally signifying an older male, a respected elder¹⁷.

R *You can have some problems with the enumerators because if they are entrenched in this culture they know that the man is obviously the head of the household. They may go to the household and ask “Where is your father?”, and not ask “Who is the head of the*

¹⁷ Female equivalents might include *nyanya*, *mama*, *gogo*, *koko*

household?”If we go to the household and find a wife and ask where is the head of the household. “Oh he is not here” if the man is somewhere else. It’s a man who is the head of the household though this particular wife may be the one who supports her family and the household.

I So the man even if he’s not the economic head he’s still seen as being more the administrative head.

R Yeah. You see, the definition is not about what takes place, it’s about the sexes. Here you have a man, and whatever is around him, then it is the household.

Tanzanian researcher / demographer UNFPA

Both survey collectors and respondents make assumptions about the role of the household head and ascribing influence to them in terms of authority, power and influence. Respondents report individuals who they consider to be the head of the household. For at least seven of the interviewed households the head of household was absent and did not sleep there the night before and in most cases had been absent for more than three months and therefore would have been excluded from most standard household surveys.. The example of Mary, interviewed in a high density suburb in Dar Es Salaam, illustrates the points made in the preceding key informant interview. Mary (44 years) is married to Nelson (46 years), who has been away in Shinyanga for two months. Nelson sends money back to Mary in Dar Es Salaam, but she does not know for how long he will be away. Mary answered the questions, but was adamant that Nelson was considered as the household head.

3.4 Theme 4: Children and old people

There is particular ambiguity about where children and widowed older people belong. Ambiguity about children is related to several factors, often in contexts of parental domestic or marital instability, insecure housing or poverty coupled with issues around schooling. De facto survey definitions would attribute these children to just one or another household, but this fails to reflect the fact that they often get support, care, resources and inputs from a range of sources, varying over time and space.

R ... you find that you have your children there but because this house is not enough they are covered under another roof. But you coordinate everything, you eat there, you share the costs, everything, including the rent of the other room where they sleep. Now if you say sleeping under one roof, you may miss out those ones. So we specify that. Even if there are some family members or the household members who don’t really sleep there but they are taken care of by that household and they are under one head of household, then they should be included in that household.

I Even if they are half a mile up the road?

R Even if they are across the road. But they are your children and you are caring for them. But we caution the enumerators when they got into this household (the one where the children are sleeping) not to count these ones or to list them. We list them here where they belong and leave them where they want to sleep.

NBS statistician / supervisor

A household from Rufiji, headed by Fatima, a 60-year old widow, highlights the fluidity of household membership for older people (fig 7). Her household includes a dependent sister and her married granddaughter’s husband, child and father-in-law.

Fig 7 Fatima’s household (Rufiji)

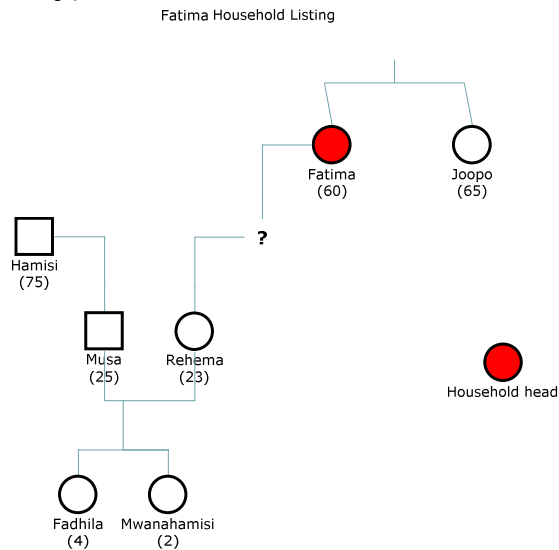

Hamisi, her grand-daughter’s father-in-law is widowed, and unable to fend for himself, his agricultural plot having “collapsed”. When Fatima was interviewed he had been staying with her for 5 or 6 weeks, consuming food from the household’s single cooking pot. The potential length of his membership of Fatima’s household was uncertain, with talk that he might go to stay with other relatives.

3.5 Theme 5: “Famous” fuzziness: pastoralists and polygyny

When key informants were asked which people were particularly problematic in terms of a survey definition of a household, the two most frequently cited groups were the polygynous and the Maasai. Maasai were seen to be problematic largely because many people perceive them to be nomadic pastoralists – despite the fact that the majority have been settled in villages for decades. The fact that Maasai are also highly polygamous renders them doubly difficult.

there was a discussion one time...yes, people wrote this question “What is a household?” And then people said “Well, a household is a group of people or individuals who eats from the same pot” This is because in some communities – like Maasai communities – are polygamous families. So if someone has 3 wives or 4 then we wouldn’t consider that as 1 household but rather where they eat from the same pot, with different wives from different households. That is one of the difficulties when you go to communities that are not, you know, nuclear families.

UDSM academic

Tanzanian key informants might have highlighted the Maasai, or polygamous populations partly as a way of distancing themselves from populations associated with “traditional practices”, aligning themselves with modernity, as distant from perceived deviant behaviour of undeveloped “others”. However survey professionals also highlighted the issue of polygamy but then resolved the issue by collecting data in a way that rendered polygamous households down to more conventional monogamous units;

We just said, OK, we’re going to look at one unit: head of household, primary spouse, primary unit of children. So it’s going to be, not, if there are two sets of wives and two sets of kids we’re not going to sample the second set – because in Tanzania it could be common – so it’s really the male head of household along with the first wife, the oldest wife or whoever he’s living with at that time, and the kids of that union or marriage. **NGO senior personnel**

Our Maasai case study interviews did demonstrate that the Maasai are particularly poorly represented by survey household definitions (Randall et al 2008). This is for a range of reasons which include polygamy and a patrilineal patrilocal residential pattern where married sons and their wives usually co-reside with their father forming a large, extended interdependent economic unit. However Tanzanian Maasai are really not nomadic at all although individuals of all ages remain highly residentially mobile, sometimes moving in what could be seen as small family nuclei (mother and children, siblings) but often dispersing conventional nuclear family units. However a key issue in understanding Maasai households is that even if they are spatially dispersed they are usually seen to be one economic unit under one head who manages the diverse resources of milk, grain, agricultural produce and livestock. Fragmenting these into units with one cooking pot or under one roof basically totally misrepresents their daily economy solidarity. Further Maasai traditions render sleeping unit and cooking pot household definitions very inappropriate: for example young warriors cannot be the only member of the age set eating from a specific pot at one meal – they will always be accompanied by another who may be sibling, kin or just friend. Furthermore young men will frequently sleep as a group away from the main homesteads.

4. Conclusions

For many survey professionals, the household has a crisp definition which is clearly bounded and with unambiguous membership criteria, reflected in the sorts of instructions that are given in interviewer training and handbooks. These boundaries become fuzzy immediately the household survey is in the field and interviewers are confronted with actual lives. The fuzziness of the concept is part and parcel of the fact that the household is a somewhat artificial construct for survey data collection, although we recognise that in some contexts the definition may match well with many people's lived reality. The problem is that the mismatching is far from randomly distributed and therefore some communities or types of people are particularly poorly represented when their basic living units are porous and permeable.

A further complication arises from the fact that 'household' is a word that is simultaneously part of common language yet is also a technical term used in surveys. It is at once a tightly defined concept defined in survey manuals and a fuzzy concept from the perspective of those people that actually live in households. There are hence multiple 'fuzzinesses': the fuzzy reality of actual life but also the fuzziness generated by misunderstandings by data users and analysts of the actual parameters of the definitions used in data collection – and the frequent assumption that because the word 'household' is used in surveys, the units described and analysed in survey reports are '*production unit [but it is also a] consumption, social and demographic unit*' .. '*central to the development process*' (modified from Republic of Kenya, 2003:59)

This paper does not reject the concept of the household as being "too limited, artificial, and abstract" (Burch, 2001: 5267). To do so would be counter-productive and rob us of a useful concept that is articulated in everyday and non-technical language. Rather, that the very complexity and flexibility of social organisation that is understood by the household as it is lived, could be better acknowledged by those that commission, produce and use these data. The size and structure of households – two key attributes for understanding and interpreting household-level data – need to be contextualised within the survey's pre-defined parameters.

The concept "household" is ambiguous. It needs to be situated in its context, and be qualified. The household is potentially very useful analytically, provided that its constraints, boundaries and parameters are placed centre stage, not just for survey respondents and data collectors, the focus of our paper here, but also, and probably more importantly, for people at other points along the commodity

chain, including the consumers of data produced by household surveys. We do not suggest that households should be excluded from comparative research across and through cultural, geographic, and linguistic borders. However harmonising household definitions does not simplify the analytic task. In fact, generic “one size fits all” household definitions may do more damage than harm if what we really want to understand and compare is how people actually live together, and, in particular manage resources and poverty, in different settings.

In reality, the household is polymorphous – it is made up of individual(s) who have allegiances and connections, to varying degrees and types, with other households. There are many, possibly a continuum of, grades of membership to a household – which makes it a fuzzy set (in mathematical terms). Membership can be blurred and indistinct, across both space and time and whereas for many survey professionals, defining who belongs to a household appears relatively straightforward, our case studies demonstrate that actually identifying the group who make joint provision for food and other essentials for living may be quite difficult.

Shedding light on the fuzziness of the household as it is used in household surveys, especially the dynamic nature of households, does not undermine the crucial importance of cross-sectional surveys – needed to produce data to monitor and evaluate progress in development. Analysts of poverty have developed fuzzy poverty measures (Cerlioli & Zani, 1990; Klasen, get date; Lelli, 2001; Qizilbash & Clark, 2005) to try to capture the “inexact or vague” notions of well-being and poverty, with imprecise cut-offs between poverty and non-poverty, and the need to shed light on the relationship between absolute and relative poverty. What is interesting about this work on the fuzzy nature of poverty is that it continues to use, unquestioningly, the household as the key organiser of indicators used, primarily because data are available from household surveys. For example, Klasen’s composite measure of deprivation includes average years of school of all adult household members, share of adult members of household employed, proportion of children stunted in household, level of satisfaction of household and number of household durables. Theorists of fuzzy poverty do not deal with the fact that the household is, itself, fuzzy.

Household size, a *de facto* outcome of the definition of the household – who is “in” and who is “out” of the household – has been studied extensively, both in its own right (Garenne, 2001) and as a determinant of other outcomes (Bongaarts, 2001). Rarely, however, do authors reflect on the issue that they are measuring or including; a number that is, by definition, an artefact of how the household was defined in the first place (for an exception see Pilon & Vignikin 2006).

Szreter (2001) argues that demography’s meticulousness with respect to data collection and analysis has been at the expense of its ability to deal reflexively with its own development and use of constructs such as the household (and family). Dealing as it does with the size and structure of human populations, an essential attribute of demography the collection, analysis and presentation of demographic data. In this respect, the “most important single instrument is the census” (Haines, 2001, 3432). It is to the census endeavour, and the efforts of the UN from the mid-twentieth Century in particular, that we must turn in order to situate current understandings of the household as it is used in surveys. Because a census is a clear-cut activity to enumerate each individual in a territory once, and to avoid double counting, household definitions in a census are fairly straightforward but information linking the individual to others are usually very limited. In the interests of comparability definitions of the household in surveys have tended to follow census operationalisation, along the lines of dwelling or housing, even though the two – census and survey – have very different aims. The census is about complete enumeration, avoiding double counting. The purpose of surveys is to provide micro-level information about individuals and their relationships with others. It is this tension between the

individual and their relationship to others that is at the heart of the conceptualisation issue when it comes to the household in surveys.

The aim of this paper was not to redefine the household nor to come up with methodologies that would allow us statistically to account for its heterogeneity or fuzziness. The in depth interviews include examples of household members being included who had never even lived in the *kaya*. However the experience we acquired interviewing key informants and household members has shed more light into straightforward approaches to fuzziness. Fuzziness cannot be perfectly resolved, nor should it be, and represents the interface between the statistical needs of the survey professional and the lived realities of households.

It is possible for household surveys to collect data in more flexible ways that allow better configurations of individuals, including moving beyond simply listing relationship to household head (however defined), to documenting detailed relationships and nuclei within the household. Such an approach is likely to better identify some of the “fuzzy” relationships, including identification of individuals otherwise likely to be forgotten. Ultimately, this approach is likely to give a much better (more realistic) picture of household structure and access to assets. Where possible, and in particular for specialized surveys, it is important to avoid assumptions of crisp boundaries to households, and instead to allow multiple membership of households (Hosegood & Timaeus 2006). By collecting both de facto and de jure information on individuals, a further dimension, of time, can be added to the more complex, but more realistic representation, of the units in which people live.

References

Antoine, Philippe, Eva Lelièvre, and groupe de réflexion sur l’approche biographique (eds.). 2009. *Fuzzy States and Complex Trajectories: Observation, Modelization and Interpretation of Life Histories*. Paris: Institut Nationale d’Etudes Démographiques.

Banks, T. (2003). Property Rights Reform in Rangeland China: Dilemmas On the Road to the Household Ranch. *World Development* 31: 2129.

Basch L, Schiller N G, Blanc C S 1994 *Nations Unbound: Transnational Projects, Postcolonial Predicaments, and Deterritorialized Nation-States*. Gordon and Breach, Langhorne, PA

Bedi, T., A. Coudouel, et al., Eds. (2007). *More than a pretty picture: using poverty maps to design better policies and interventions*. World Bank.

Bender D R 1967 A refinement of the concept of household: Families, co-residence, and domestic functions. *American Anthropologist* 69: 493–504

Bolt, V. J. and K. Bird (2003). "The Intrahousehold Disadvantages Framework: A Framework for the Analysis of Intra-household Difference and Inequality." Chronic Poverty Research Centre. Working Paper 32.

Bongaarts, J. (2001). "Household size and composition in the developing world in the 1990s." *Population Studies* 55(3): 263-279.

Brown, S. L. and W. D. Manning (2009). "Family boundary ambiguity and the measurement of family structure: the significance of cohabitation" *Demography* 46(1): 85-101.

Bruce J, Lloyd C 1992 *Finding the Ties that Bind: Beyond Headship and the Household*. Population Council International Center for Research on Women, New York

Burch, T. K. (2004). *Families and Households, Behavioral Demography of*: 5265.

Cerioli A. et Zani S., (1990), «A Fuzzy Approach to the Measurement of Poverty», in Dagum C. and Zenga M. (eds.), *Income and Wealth Distribution, Inequality and Poverty*, Springer Verlag, Berlin, pp. 272-284.

Coleman, D. (2004). *Migration in the 21st Century: a third demographic transition in the making?* Plenary address to the BSPS. BSPS Annual Conference. Leicester.

Currie, G. and J. Stanley (2008). Investigating Links between Social Capital and Public Transport. *Transport Reviews: A Transnational Transdisciplinary Journal*, 1464-5327, Volume 28, Issue 4, 2008, Pages 529 – 547

Danson, M. W. (2007). Fuzzy concepts, scanty evidence, policy distance: the case for rigour and policy relevance in critical regional studies. *Regional Studies*. 41: 175-190.

Descola, P. (2005). Sur la connaissance anthropologique. On anthropological knowledge. *Social Anthropology* (2005), 13, 1, 65–73

Duncan, t. (2008) "household surveys." *The New Palgrave Dictionary of Economics*. Second Edition. Eds. Steven N. Durlauf and Lawrence E. Blume. Palgrave Macmillan, 2008. *The New Palgrave Dictionary of Economics Online*. Palgrave Macmillan. 28 July 2009
http://www.dictionarofeconomics.com/article?id=pde2008_H000160

Eriksen, T. H. (2007). Complexity in social and cultural integration: Some analytical dimensions. *Ethnic and Racial Studies* 30: 1055-1069.

Garenne, M. (2001) *Gender asymmetry in household relationships in a bilinear society: the Sereer of Senegal*. Paper prepared for the virtual conference on African households: an exploration of census data University of Pennsylvania, Center for Population Studies November 21-23, 2001.

Gereffi, G., M. Korzeniewicz, R. P. Korzeniewicz (1994) "Introduction to Commodity Chain and Global Capitalism" Praeger.

Goldstein, H., J. Rasbash, et al. (2000). "Multilevel Models in the Study of Dynamic Household Structures." *European Journal of Population* 16: 373-387.

Haines (2001)

Harpham T; Scott C (1987) "Sample implementation" in *In: The World Fertility Survey: an assessment*, edited by John Cleland and Chris Scott in collaboration with David Whitelegge. [London, England], International Statistical Institute by Oxford University Press, 1987. :347-78.

HOFFMEYER-ZLOTNIK Jurgen HP, WARNER Uwe 2008. Private Household concepts and their operationalisation in National and International Surveys. *Survey Methodology* Volume 1, GESIS-ZUMA, Mannheim

Hoosegood, V & Timaeus, I. (2006) Household composition and dynamics in KwaZulu Natal, South Africa: mirroring social reality in longitudinal data collection in 'African Households: Censuses and Surveys' van de Walle, E. (2006) M.E. Sharpe (Armonk, NY) :58-77

Hyowon, Ban. and A. Ola (2009). Representing and negotiating uncertain geospatial concepts – Where are the exurban areas? *Computers, Environment and Urban Systems* 33: 233.

Imhoff, E., Ed. (1995). Household demography and household modelling. The Springer Series on Demographic Methods and Population Analysis

Keilman N W 1995 Household concepts and household definitions in Western Europe: Different levels but similar trends in household developments. In: Van Imhoff E, Kuijsten A, Hooimeijer P, Van Wissen L (eds.) *Household Demography and Household Modelling*. Plenum, New York London

Klasen, S. (2000) "Measuring poverty and deprivation in South Africa" *Review of Income and Wealth* 46: 33-58

Knab (2005).

Lelli (2001)

Murphy, M. (1996). The dynamic household as a logical concept and its use in demography. *European Journal of Population* 12(4):363-81.

Muula, A. (2007). How do we define 'rurality' in the teaching on medical demography? *Rural and remote health* 7: 653.

Naidoo AGV, Yadavalli VSS, Crowther NAS: 2005. A multi-dimensional measure of poverty using the totally fuzzy and relative approach. *Studies in Economics and Econometrics/ Studies in Economie en Ekonometrie (SEE)*, 29 (3), pp 67-80.

Netting R McC, Wilk R R, Arnold E J (1984) (eds.) *Households: Comparative and Historical Studies of the Domestic Group*. University of California Press, Berkeley and Los Angeles

Ngwane, A. K., V. S. S. Yadavalli, et al. (2001). Poverty in South Africa in 1995--A Totally Fuzzy and Relative Approach. *Journal for studies in Economics and Econometrics* 25: 77-87.

Philipov, D. "Data Resources: Comparative Data on Demography and Migration", from http://www.nessie-essex.co.uk/dataResources_demogMigration.asp.

Phillis, Y. A. and L. A. Andriantiatsaholiniaina (2001). Sustainability: An Ill-Defined Concept and Its Assessment Using Fuzzy Logic. *Ecological Economics* 37: 435-56.

Pilon Marc, Vignikin Kokou (2006) Ménages et Familles en Afrique subsaharienne. Archives contemporaines

- Qizilbash, Mozaffar and David Clark. 2005. The capability approach and fuzzy poverty measures: an application to the South African context. *Social Indicators Research*, **74**, 103–39.
- Randall S, Coast E, Leone T 2008 'Une culture disciplinaire et ses pièges : l'emploi du terme « ménage » en démographie'. Paper presented at AIDELF : Colloque Démographie et Culture, Québec, August 2008, <http://www-aidelf.ined.fr/>
- Republic of Kenya, Ministry of Planning and National Development 2003/4-2007/8 Strategic Plan for National Statistical System, March 2003
- Ribot, J. , 1998 , Theorising access: Forest profits along Senegal's charcoal commodity chain. *Development and Change* 29 , 301 – 341
- Rogers, Beatrice Lorge. "The Internal Dynamics of House-holds: A Critical Factor in Development Policy." Mi-meographed. Medford MA: School of Nutrition, Tufts University, Oct. 1983.
- Smart, A. (2003). "Sharp edges, fuzzy categories and transborder networks: managing and housing new arrivals in Hong Kong." *Ethnic and Racial Studies*, 26: 218-233.
- Szreter. (2001). "What's wrong with contemporary economics?" *Interdisciplinary Science Reviews* 27: 13-24.
- Thornton, Arland and Thonzas E. Fricke. 1989. "Social Change and the Family: Comparative Perspectives from the West, China and South Asia." Pp. 128-61 in *Demography as an Interdiscipline*, edited by J. Mayone Stycos. New Brunswick, NJ: Transaction.
- United Nations. Statistical Division 1998 *Principles and Recommendations for Population and Housing Censuses, Revision 1*. United Nations, Department of Economic and Social Affairs, Statistics Division, Statistical Papers Series M No. 67_Rev.1, New York
- van de Walle E.(2006) Introduction in: *African Households: Censuses and Surveys* ed. E. van de Walle, ME Sharpe, New York
- Voas, D. (2009). "The rise and fall of fuzzy fidelity in Europe." *European Sociological Review* 25(2): 155-168.
- Willis, G.B. (2004) *Cognitive Interviewing: A Tool for Improving Questionnaire Design*. (Ed.), Thousand Oaks, CA: Sage, 2004
- Wolff, Kristina. "Methods, Case Study." *Blackwell Encyclopedia of Sociology*. Ritzer, George (ed). Blackwell Publishing, 2007. Blackwell Reference Online. 28 July 2009
- World Bank (2008). 2008 WORLD DEVELOPMENT INDICATORS: Poverty data: A supplement to World Development Indicators 2008.
- Yanagisako S J 1979 Family and household: The analysis of domestic groups. *Annual Review of Anthropology* 8: 161–205